

KLR Beer Filter USER MANUAL



www.klrfilter.com

Introduction

Thanks for buying this product! The base was hand-machined out of solid PVC plastic, which is highly durable. The plastic filter body creates the perfect method for sealing the unit while pressing the ends of the filter cartridge, forcing your beer to go through the filter cartridge for great results.

This kit can also be used to filter wine, mead, and other home brews using finer micron filter cartridges, which are available at klrfilter.com. The beer kit came with a 10 and 20 micron filter cartridge, which are typically used for beers. You may want to filter using the finer micron filters.

Additional directions and instructional videos are available online at klrfilter.com.

Warranty

The KLR Filter is guaranteed against defects for 30 days after the date of purchase. If the filter fails to perform as advertised within those 30 days, simply return everything undamaged for a full refund.

Parts and Filter Cartridges

Replacement parts are available at klrfilter.com. Filter cartridges come in 1, 5, 10, 20, and 50 micron filtration capabilities. All cartridge filters fit this filter kit.

Comments/Questions

Please use our website to send us questions or comments. Click on the Contact Us tab at the top of the home page.

Uses

The 10, 20 and 50 micron filters are typically used for filtering beer, whereas wine filtering uses the 1 or 5 micron filter cartridges. All KLR filter cartridges fit the KLR Filter.

Beer filtering typically occurs after transferring to the second carboy and secondary fermentation is complete. It is recommended you start with a 50 micron filter for extremely heavy hops or higher particle brews, but normally the 20 microns work well for the first filtering. Once the beer is run through a 20 micron filter, you can work down using finer filters to your preferred clarity.

List of Cautions

- Disassembly of the fitting on the filter body voids the warranty. If the top body inflow fitting is removed, please test it for leaks prior to filtering a precious batch of home brew.
- Use only for filtering home brews. This unit is not intended for filtering sprints and other liquids.
- **Do not pressurize the filter body.** This product is designed for gravity feed filtering only.
- If you disassemble the filter, keep small parts out of reach of children and pets.
- Use only as designed and per these instructions.
- Clean after each use. **Never use detergent-based soap on any brewing equipment.**
- Prior to use, rinse the inside and outside of the filter unit with a potassium metabisulfite solution as you would with any home brew equipment.
- Do not store liquids in the filter when not in use. It is recommended that you leave the unit apart to air dry between uses.
- Filter cartridges are not reusable. Discard after each batch of home brew has been filtered.
- Use only 1 filter cartridge per batch of brew to eliminate the potential for cross-contamination.
- Do not leave filters exposed to open air for long periods of time. They might pick up germs and microbes that could negatively impact your results.
- Beer tends to have larger particles, and filter changes may be required due to heavy sediment typically found in home brewed beers.
- The maximum amount of beer that has been test filtered through a single filter cartridge is 20 gallons. It is recommended that you replace the filter cartridge if filtering more than 20 gallons of liquid.

KLR Filter Parts and Diagram

The diagram below provides a view of the parts provided in your filter kit and also how the filter is assembled. Please see the videos on our Web site for more tips and instructions for using the KLR beer filter.

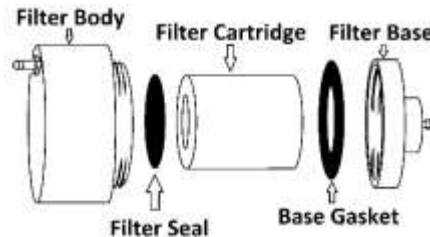

Filter Body

The filter body is the clear plastic part with a barbed fitting to one side.

NOTE: The barbed fitting is canted at a slight angle on purpose. Removing or straightening the body barb fitting voids the warranty and makes you upset for not reading these directions. Plus you potentially ruined a great filter system!

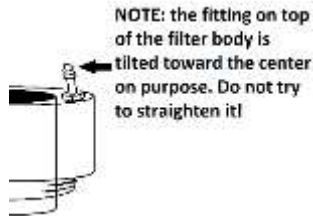

Filter Seal

The filter seal is a solid black rubber disk. It sits on top of the filter cartridge element when assembling to provide a seal between the filter cartridge and the filter body. You received an extra one of these in your filter kit. Wash completely prior to use as they may have talc on them.

Filter Cartridge

The filter cartridge is a cylindrical filter made from spun plastic filaments. There are 2 sizes of filters in the beer filter kit. The filter marked 20 micron is a rough filter and is used for the first filtering of your beer. After initial filtering, additional filtering can be done using the 10 micron filter cartridge that was included in the beer filter kit.

NOTE: There may be loose fibers on the filters and in the center hole. Inspect and rinse prior to use. If loose material can be picked off with your fingers, please do so. We air cleaned them prior to shipping but please look them over before use!

Base Gasket

The base gasket is a rubber ring that fits snugly into the filter base, and a spare one was provided. Wash completely before use as they may have talc on them.

Filter Base

The filter base is the heavy piece of gray PVC with a threaded barb on the bottom of it. This is the hand-machined piece of the kit.

CAUTION!

Threads are hand machined and may be sharp. Take caution not to get cut when putting in the gasket or cleaning the base.

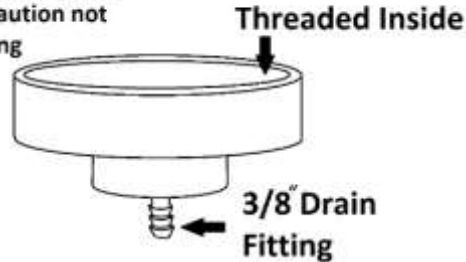

Directions for Use

1. While the filter base and filter body are apart wash all parts with sanitizer or a brew equipment cleaning solution. Any solution you use to clean brewing equipment will also work for this filter unit.

NOTE: Never use detergents, dish soaps or other types of common soaps to clean the KLR Filter or any of your brewing equipment. These soaps tend to leave residues that adversely impact the quality, smell, and taste of your home brews.

2. Rinse the KLR Filter base gasket, filter seal, filter body and filter base with pure water. Then lightly spray with, or rinse in, a potassium metabisulfite solution.

NOTE: Chlorine, which is commonly found in tap water, imparts unwanted flavors and aromas to home brews. Minimize the use of tap water for rinsing your brewing equipment or for adding water to top off brews.

3. Insert the base gasket into the filter base. It fits under the threads and there may be a small bump after you have pushed it in all around. Simply work it into the recess until it is smooth and flush with the filter base.

CAUTION!

Threads are hand machined and may be sharp. Take caution not to get cut when putting in the gasket or cleaning the base.

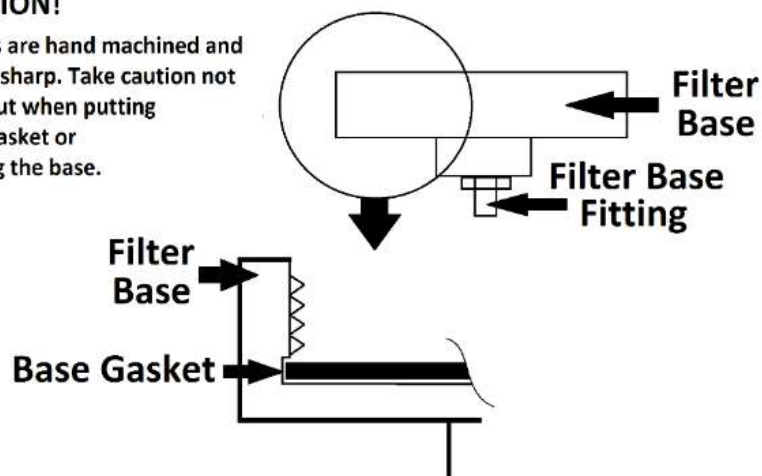

4. Remove a new filter cartridge from the protective wrapper. Inspect it for any loose particles that may have remained after we air cleaned it. Remove any loose bits of filter cartridge with your fingers. Rinse it off if needed.

5. Spray the entire filter cartridge with a potassium metabisulfite solution to minimize the potential for inadvertently introducing contaminants to your brew.
6. Place the filter inside the filter base within the circular slot in the center of the base.
7. Place the filter seal on top of the filter.

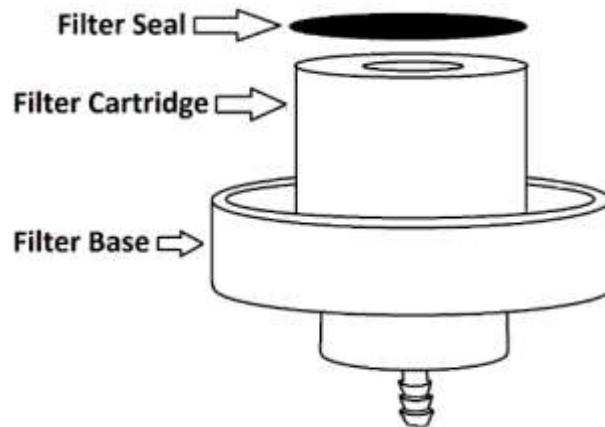

8. Screw the filter body onto the base while keeping the filter seal centered on the filter cartridge (see diagram, page six and cover page picture). **DO NOT OVER TIGHTEN!** Make it snug enough to provide a seal, but not so tight that you can't get it apart. If you accidentally overtighten it, run some hot water around the threads to help loosen it.

NOTE: The filter seal can be slightly off-center. The main purpose of the seal is to cover the center hole of the filter cartridge. This forces liquid through the filter cartridge wall.

Top View, filter seal centered

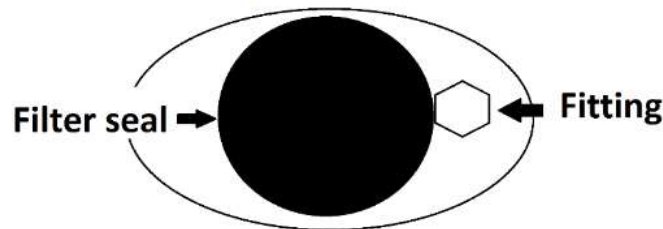

This is okay, as is the one in the image below:

Top view, filter seal slightly off-center

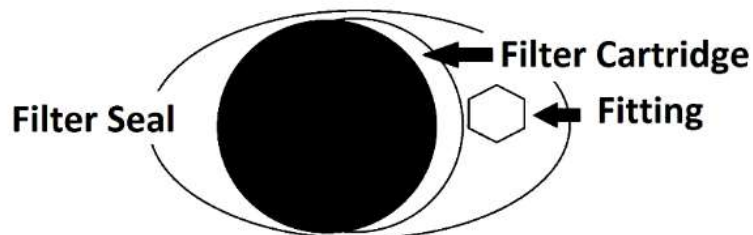

In the image below, the filter seal is so far over that it allows part of the filter cartridge hole to show. THIS WILL NOT WORK! It will allow your brew to go through the middle of the cartridge without being filtered.

NOT GOOD!

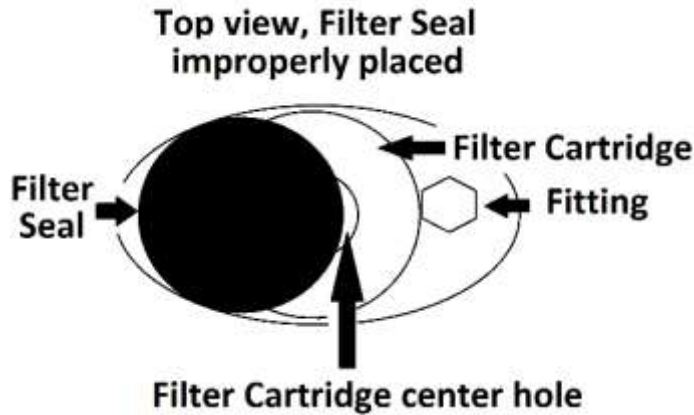

9. Hand tighten only. Ensure the base and body are firmly attached to each other. This will prevent your brew from leaking around the base.

10. Look through the top of the filter body to ensure the filter seal covers the center hole of the filter cartridge.

11. Connect a 3/8" tube (not supplied) to the bottom of the filter base fitting for the receiving carboy.

NOTE: This unit relies on gravity feed and is not intended for pressurized use. Thus it is advised you only push the hoses over the first ridge of the fitting. This will make removal easier.

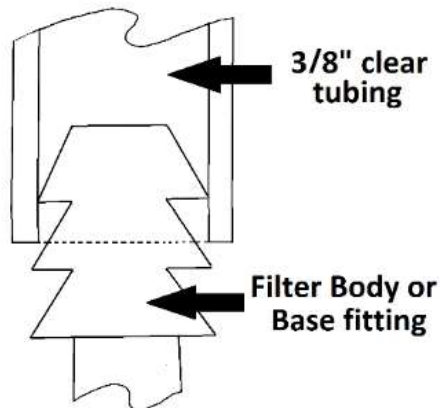

12. Set the filter unit on top of the carboy and position the carboy to receive the filtered brew from the first source (see diagram on page 14).

13. For beer it is recommended a carboy with a tap at the bottom is used. This is because beer tends to have a lot of CO₂ present, which can cause a siphon to vapor lock. Gravity feeding out of the bottom of the carboy works much better. Connect the top 3/8" tubing (not supplied) to the filter body fitting and tap. If 3/8" is too small, use a small piece of larger piece tubing to make a connector. All normal sizes of tubing you find in your brew making supply store will fit inside the next larger size perfectly.

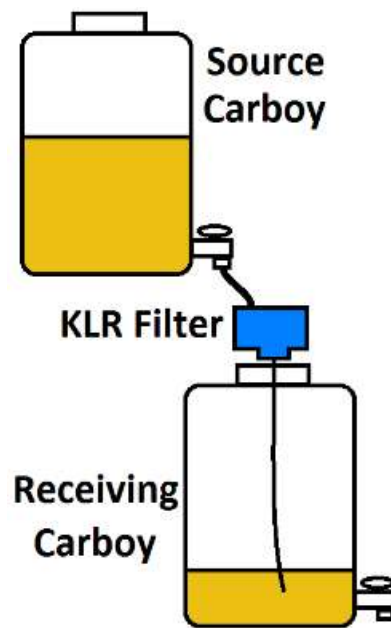

14. If your tap is too large for the 3/8" tubing, simply cut a small piece of larger hose and use it as the connector.

TIP: I finally figured out that each successively smaller or larger standard clear plastic tubing you find in your supply shop fits inside the next higher or lower size. For instance, the 1/4" inner diameter tubing fits perfectly into the 3/8" inner diameter tubing. The 3/8" inner diameter tubing fits perfectly into the 1/2" inner diameter tubing. You can use them to adjust the tubing end size to fit whatever you need to connect to without buying fancy adapters. For those of you who already knew this...please skip this tip.

15. Use your racking cane or siphon apparatus to start the flow of liquid to the KLR Filter unit.

NOTE: Some folks simply suck on the clear plastic tubing to get the flow started. If you do this, try not to leave a large air bubble pocket at the top. It will cause the filtering to go slowly. If no air is in the tubing to the filter, the filtering goes much faster.

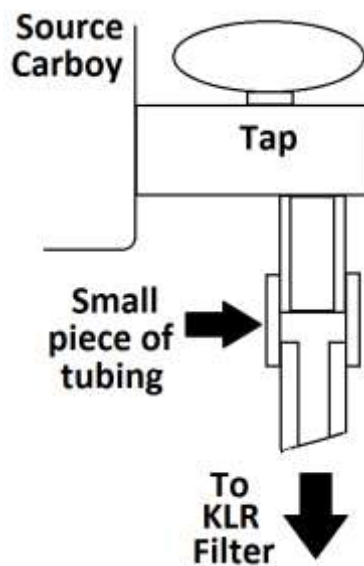

15. Turn the tap to the open position to start the flow of liquid to the KLR Filter unit.

16. Once liquid is flowing to the filter, monitor it to make sure filtering is working properly. Some beers are extremely heavy with sediment, requiring a change of filter cartridges. This is due to the presence of hops and malt sediments.

17. Once filtering is complete remove the filter unit from the top of the carboy.

18. Disassemble the KLR Filter.

NOTE: If it is difficult to unscrew the filter body from the filter base, run some hot water around the joint where they screw together. It will loosen up enough to disassemble.

19. Discard the filter cartridge (you can put it in the recycle bin!).

20. Clean the filter unit as described above.

21. Dry the unit and store in a plastic bag or other protective enclosure until next use.

See klrfilter.com for instructional videos and FAQs

For additional information, instructional videos, replacement filter cartridges, or replacement parts visit:

klrfilter.com